



The Linux Storage People

EtherDrive® VS21 VirtualStorage Appliance

The Linux Storage People

SUMMARY

- AoE Logical Volume Management
- 2U rack mounted appliance
- Storage access speed increases as storage pool grows
- Up to 255 AoE LVs of any size
- LVs can be dynamically resized"
- LVs can be masked and assigned to specific servers
- LVs can be shared when using a cluster filesystem
- PVs can be synchronously mirrored
- LVs can be used for snapshots*
- Simple command line interface
- Fast LBA translation using redirection without caching
- Parallel VS21's multiple speed and provide redundancy



Logical Volume Management Terms

- *Physical Volume (PV) - an AoE target device, a disk, or a RAID volume of disks, also referred to by Coraid as a physical LUN.*
- *Volume Group (VG) - a group or pool of PV's. Volume Groups are divided up into small chunks called Extents.*
- *Physical Extent (PE) - when VG's are created, their Physical Volumes are divided into chunks called Physical Extents. (PE's can be 4, 8, 16 or 32MB)*
- *Logical Volume (LV is similar to a Logical Unit Number or LUN) - Each Logical Volume is a group of Extents taken from a Volume Group. (ie. PE's from the VG pool)*

Virtual Storage Appliance

Coraid is proud to introduce the EtherDrive® VS21 VirtualStorage™ Appliance, a Logical Volume Manager for AoE storage. The VS21 is an in-band appliance using the open ATA-over-Ethernet (AoE) storage protocol to provide, block level, storage virtualization. AoE moves a disk drive onto a network connection, and the VS21 allows a pool of physical disks to be combined into virtual storage volumes (Logical Volumes (LVs) or LUNs). Servers connect to LVs via ordinary Ethernet connections using a standard AoE driver. AoE is simpler and faster than iSCSI and does not require TCP/IP processing or expensive Fiber Channel network adapters.

Logical Volume Management is a method of storage virtualization that is filesystem independent. So, it naturally works with any OS on any host. Logical Volume Management improves storage utilization and makes a pool of physical storage easily allocatable for any application.

The EtherDrive® VS21 VirtualStorage™ Appliance takes full advantage of the simplicity of the AoE storage protocol to perform AoE redirection and fast "on the fly" block address translation for EtherDrive disk storage. The VS21 enables Physical Volumes (RAID volumes) (PVs) to be synchronously mirrored across multiple storage chassis for complete hardware failure protection. PV's are assembled into Volume Groups and divided up into small chunks called "Extents". These extents are pooled in Volume Groups and allocated to create Logical Volumes (LVs) of any size.



The Linux Storage People

EtherDrive® VS21

VirtualStorage Appliance

The Linux Storage People

Simple Storage Virtualization

The VS21 uses a simple 2 step process to create Volume Groups from a pool of Physical Volumes and then create Logical Volumes (LVs) by allocating Extents from the Volume Group. You just decide how big you want the LV to be and the Extent allocation is automatically done to provide maximum reliability.

A primary benefit of storage virtualization is the efficient use of all the physical disks in the pool. With the VS21, LVs can be any size and can be dynamically re-sized at any time without taking the LV out of service. As storage needs grow, new Physical Volumes can be easily added to the SAN and allocated to new or existing Volume Groups and Logical Volumes.

EtherDrive® VirtualStorage™ LVs are AoE target devices, just like any other AoE storage device on the network. But with LVs, you have the flexibility to slice and dice the storage exactly to your application needs, independently of the actual size of the physical disks that are in the storage pool.

LVs can be used with any filesystem or as raw block devices, just like a normal hard disk drive. And since LVs are accessible by any host connected to the storage network, they can be shared to provide better data access reliability.

Scalable Performance

The EtherDrive® VS21 VirtualStorage™ Appliance is connected to an AoE storage network with a standard Ethernet connection. VS21 uses a special technique of redirection and “on-the-fly” block address (LBA) translation without being continuously in-line with the host’s read/write data flow. This enables the VS21 to perform storage virtualization and also allows access speed to increase as the physical storage pool grows. The VS21 is equipped with two 1GigaBit Ethernet ports, however aggregate LUN read/write speed can

greatly exceed the bandwidth of these connections. Operating two or more VS21’s in parallel, multiplies the system performance and provides system fault tolerance.

Advanced Features

The VS21 learns all Logical Volume Management configuration by reading data from the AoE storage that it manages. This makes maintenance easier, if a VS21 is ever replaced.

LV masking, based upon MAC address, can be enabled to restrict access to authorized hosts.

LVs can be mirrored (replicated) by another LV, or used to create a frozen in time snapshot of an LV.

Extent size used by a Volume Group can be set to 4, 8, 16 or 32 MBytes.

EtherDrive® VS21 VirtualStorage™ Appliances can be operated in parallel to provide complete fail over redundancy and scalable performance.

Legacy System Support

VS21 can be added to an existing EtherDrive® AoE storage network and legacy volumes can become converted to LVs without copying data.





The Linux Storage People

EtherDrive® VS21 VirtualStorage Appliance

The Linux Storage People

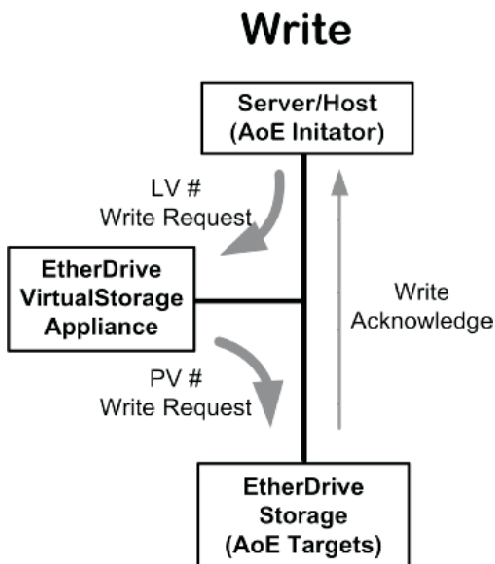
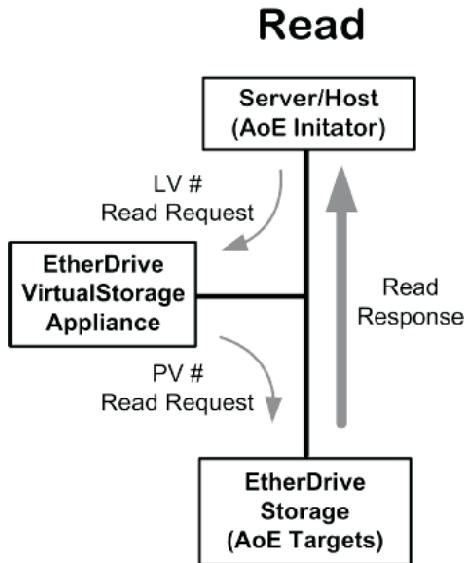

Flexible Storage Allocation

Each VS21 can create and manage up to 255 separate LVs (LUNs). LVs are more flexible than disk partitions. Each LV can be dynamically resized to any capacity without taking the LV off line. LVs can be masked and allocated to only selected servers/hosts, or shared by multiple hosts when using a cluster filesystem.

LVs can be replicated by other LVs to provide asynchronous data replication without external software. LVs can provide frozen in time snapshots* of other LVs. The VS21 also provides simple tools for data movement* between LVs. LVs may span many EtherDrive storage appliances creating large volumes.

On-the-fly LBA Translation

The VS21 processes AoE protocol frames with redirection and on-the-fly without caching write data or even touching read data. This makes performance scalable with very low latency.

Parallel VS21's multiple performance and provide redundancy.





The Linux Storage People

EtherDrive® VS21 VirtualStorage Appliance

The Linux Storage People

Flexible Storage Virtualization

EtherDrive® Storage and the AoE protocol, have a proven history of providing fast and reliable storage for any application. Adding Logical Volume Management to an AoE SAN opens a new degree of flexibility for your storage system. AoE Logical Volumes are fast, elastic disk drives that can be re-sized, and re-purposed as your storage needs change.

The process is simple. Physical disks installed into EtherDrive® Storage™ Appliances are assembled into physical RAID volumes. These Physical Volumes can be managed by an EtherDrive® VS21 VirtualStorage™ Appliance connected to the AoE SAN. Configuration is simple too. The first step is to define Volume Groups and assign Physical Volumes to each Volume Group (note:

the VS21 can also mirror two PV's located in separate storage chassis providing complete synchronous data redundancy). Physical Volume's are automatically divided into Physical Extents (user can specify Extent sizes of 4, 8, 16 or 32 MB). Then a Logical Volume is created by defining its storage capacity and selecting which Volume Group is to be used. Physical Extents are automatically selected from the Volume Group to create the desired LV size using an algorithm designed to achieve the best possible LV reliability. LVs are then put on-line and accessed by any server/host on the AoE SAN, just like any other AoE storage device.

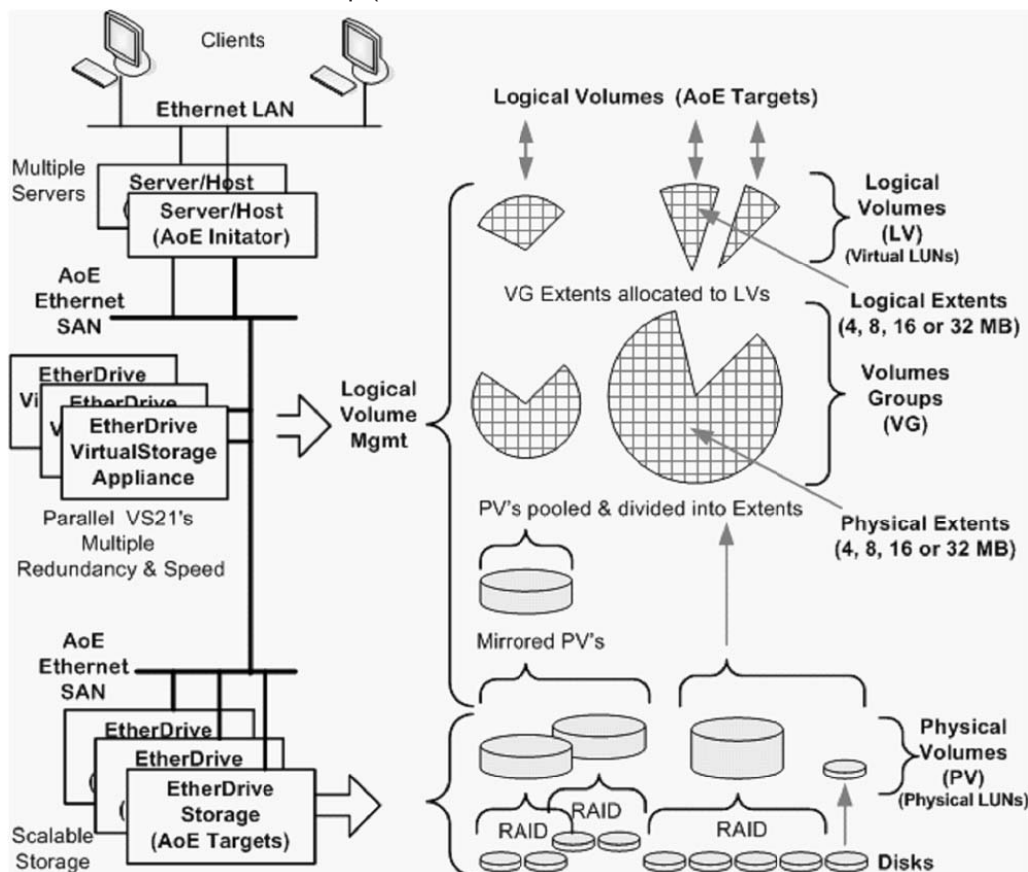



The Linux Storage People

EtherDrive® VS21

VirtualStorage Appliance

The Linux Storage People

SPECIFICATIONS

Number of AoE Logical Volumes** Managed	up to 255 AoE Logical Volumes (LV)
Number of Volume Groups Managed	unlimited
Physical Extent Size Selection	4, 8, 16 or 32 MBytes/Extent, (default 4 MB)
Maximum Logical Volume capacity	determined by Extent size selected - with 4 MB Extents aggregate limited to 333 TeraBytes with 32 MB Extents aggregate limited to 2.66 PetaBytes
Control Interface	RS-232, KVM command line interface
Network Interface	two 1 Gigabit Ethernet, RJ-45 (AoE SAN must support jumbo Ethernet frames)
Storage Access Speed	Limited by Physical Volume performance
Advanced Features	MAC address filtering PV Synchronous Mirroring LV Asynchronous Replication *LV snap shots (copy on write) *LV move from one VG to another (data migration) Active/Active redundancy and load sharing
Power Supply	100-240 VAC, 50/60Hz Redundant hot swap power modules
Cooling	4 cold swap fans
Power Consumption	< 300 Watts, heat load < 1000 BTU
Shelf Dimensions	16.8 x 3.47 x 16 inches, 20 lbs
Boot Media	FLASH (no disk)
Operating Temp	50-95 degrees F (10-35 degrees C)
Relative Humidity	20%to 90%(non-condensing)
Warranty	36 Month

* snap shot and data migration not supported in initial firmware release.

** AoE Logical Volumes are similar to LUNS, but they are not SCSI devices.